

DATASHEET



Name Suspension light

Type Jack O'Lantern Large

ID PC1097

Description The Jack O'Lantern collection by designer Lucie Koldova offers a high degree of variability and provides space to create lighting compositions based on personal preference. The glass sphere is an integral component of the Jack O'Lantern pendent light and cannot be ordered separately. While the spheres must always be placed in metal frames, single frames can be hung empty in vertical arrangements with another frame and sphere.

Tech. description The light comprises a glass sphere and metal endcap with G9 lamp socket. The light is intended for use with cage PC1102. The magnetic ring holding the endcap in place is not designed to bear the weight of the glass sphere.



CONSTRUCTION SPECIFICATION

Weight [kg]	1.5 kg
Construction material	glass, metal
Cord length [mm]	2,200 mm
Mounting	ceiling
Environment	indoor

ELECTRICAL SPECIFICATION

Input voltage [V]	230 VDC
Frequency [Hz]	50-60 Hz
Max. power [W]	10 W
Coverage IP	20
Socket	G9
Light source	-
Energy class	A+ to B depending on light source

Dimensions [mm]

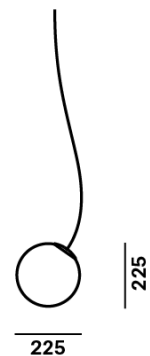

Certifications



DATASHEET

RECOMMENDED BULBS

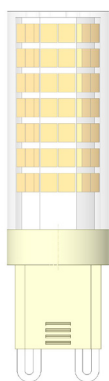
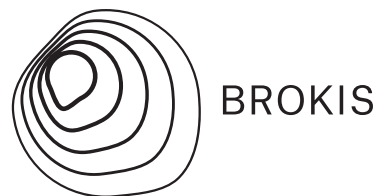

LAMPJA G9 5 SCPD 827

Socket	G9
Type	LED
Lamp wattage [W]	4.5 W
Input voltage [V]	220-240 VAC
Energy class	A+
Flux[lm]	399 lm
Light colour [K]	2,700 K
CRI	80+
Lifespan [h]	15,000 h
Dimmable	yes (triac)
Dimensions h x w [mm]	54 x 18 mm

Ceiling canopy

Dimensions \varnothing x w [mm]	90 x 70 mm
Weight [kg]	0.2 kg
Material	metal



Drawing

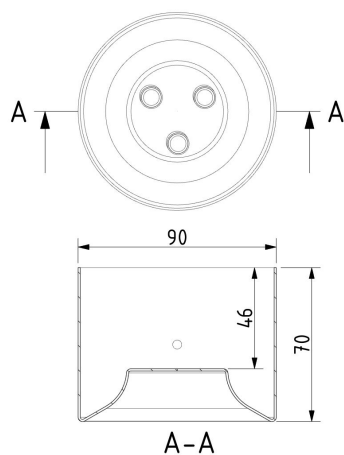

Canopy bracket

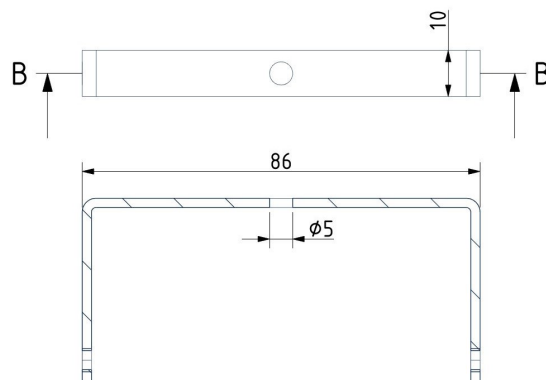

TECHNICKÝ LIST

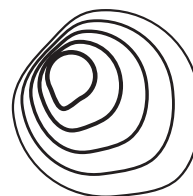

BROKIS

Název	Závěsné svítidlo
Typ	Jack O'Lantern Large
ID	PC1097
Popis	Kolekce Jack O'Lantern nabízí mnoho variabilních možností a otevírá prostor pro vytvoření kompozic dle osobních preferencí. Skleněná koulička je součástí závěsné verze svítidla Jack O'Lantern, z kolekce designérky Lucie Koldové, a nelze ji objednat jako samostatnou položku, ale vždy pouze ve spojení se samostatnými kovovými rámy.

Technický popis Svítidlo je složeno ze skleněné koule a kovové patice s objímkou G9. Toto svítidlo je určeno k uložení do klece PC1102. Magnetický prsteneček, kterým je uchycena patice, není určen k vynesení hmotnosti skleněné koule.



KONSTRUKČNÍ SPECIFIKACE

Hmotnost [kg]	1.5 kg
Použité materiály	sklo, kov
délka připojovacího vodiče [mm]	2,200 mm
Montáž	strop
Prostředí	Vnitřní

ELEKTRICKÁ SPECIFIKACE

Jmenovité napětí [V]	230 VDC
Frekvence [Hz]	50-60 Hz
Max. příkon [W]	10W LED
Krytí IP	20
Patice	G9
Světelný zdroj	-
Energetická třída	A+ až B dle použitého zdroje

Rozměr [mm]

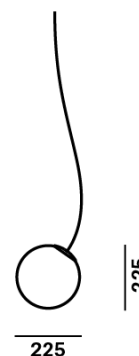

Certifikace



TECHNICKÝ LIST

DOPORUČENÉ SVĚTELNÉ ZDROJE

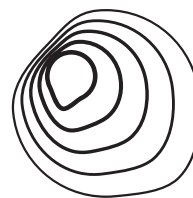

BROKIS

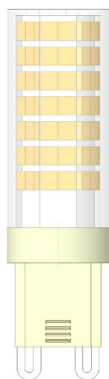

LAMPIA G9 5 SCPD 827

Patice	G9
Typ	LED
Příkon [W]	4,5 W
Vstupní napětí [V]	220 - 240 VAC
Energetická třída	A+
Světelný tok [lm]	399 lm
Barevná teplota [K]	2700 K
CRI	80+
Životnost [h]	15,000 h
Stmívatelnost	ano (triac)
Rozměry v x š [mm]	54 x 18 mm

STROPNÍ BALDACHÝN

Rozměry \varnothing x v [mm]	90 x 70 mm
Hmotnost [kg]	0.2 kg
Materiál	kov



Nákres

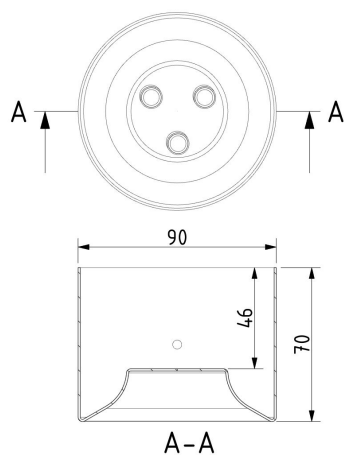

Držák baldachýnu

